



G5 VOODOO NEO 6

Quick Start Guide

Version 2

IMPORTANT INFORMATION

Link ECUs are shipped locked

All Link ECUs are shipped locked and must be unlocked before they can be used. The ECU can be installed and configured using PCLink, but will not read engine RPM or run the engine until it is unlocked. Please contact your official Link ECU supplier to obtain an unlock code.

PCLink software

All Link ECUs are tuned and configured using our PCLink software. Connection to the ECU is established through on-board USB, Ethernet, or Wi-Fi.

The latest version of PCLink can be downloaded from linkecu.com. Included with PCLink are the USB drivers for connecting to the ECU.

After installation, consult PCLink Help (**press F1**) for instructions on connecting to the ECU.

Once you have the ECU connected to PCLink, check the ECU firmware and upgrade to the latest version.

Support options

There are a range of ways to find information and support for installing and using your ECU:

- PCLink help – **press F1** while running PCLink. Includes help on wiring, PCLink and ECU functions.
- Link ECU Knowledge Base for more technical details on this product: kb.linkecu.com/ecu-kb/latest
- Dealers – a dealer list is available on linkecu.com
- Online Discussion Forum: forums.linkecu.com
- Link website: linkecu.com
- Technical Support email: tech@linkecu.com

Product and software manuals are available at:
linkecu.com/software-support/



Product knowledge base available at:
kb.linkecu.com/ecu-kb/latest



ECU mounting guidelines

The following requirements should be taken into account during installation:

- The ECU should be fitted inside the vehicle cabin in a location that avoids exposure to excessive temperatures and the risk of water ingress. The location of the ECU should also be physically separated from the ignition components or any other components that may cause interference.
- Allow enough room for the main wiring harness and tuning cables to be connected.
- For motorsport applications, the ECU should be located in a position that minimises the risk of physical damage in the event of the vehicle being involved in a crash. ECUs used for speedway applications should be mounted securely within the cockpit area, protected from the elements and isolated from vibration.
- Please refer to the Wiring Information section in PCLink Help for additional information.

Limited Lifetime Warranty

We stand behind what we sell, and our Limited Lifetime Warranty means no tricks, no catches. If an ECU breaks in the normal course of it's designed use then we will repair or replace, no questions asked.

For full details, please visit:

linkecu.com/about/legal/lifetime-warranty/

The legal use of our products

Link Engine Management products should not be used where installation and tuning of such products contravenes your countries laws, interferes with the vehicle's safety or pollution protection features, or bypasses, defeats, or renders inoperative any emissions control system.

***EXHILARATION
STARTS HERE***

MOUNTING INFORMATION

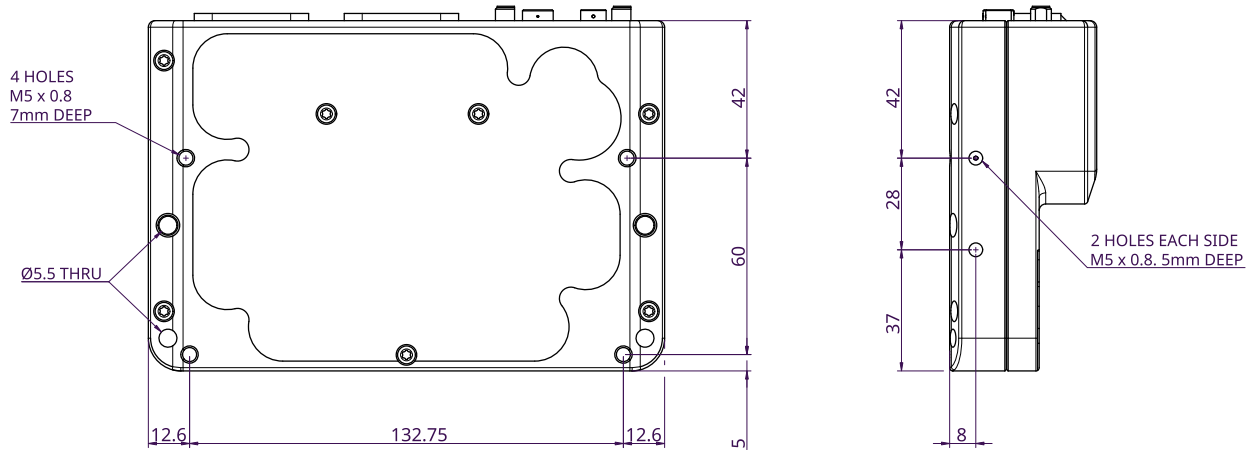

Several mounting options have been designed into the case:

- 4x Through-holes to suit M5 bolts.
- 4x Side mount M5 threaded holes.
- 4x Underside mount M5 threaded holes.

3 lengths of M5 button head cap screws have been included in the box to cover most mounting scenarios.

DO NOT make use of the threads in the mounting through-holes, these are included only for servicing, and are not intended for mounting (They are intentionally an uncommon thread size).

- Recommended torque for mounting screws is 3 Nm (25 in-lb, 2.2 ft-lb).
- It is recommended that the ECU is rubber mounted in order to isolate the ECU from vibration.

WIRING INFORMATION

Power

- Pin A5 is the main ECU power input. It can be supplied with either switched or constant VBat.
- Pin A6 is the ignition switch input. It must be connected to a switched battery source. The ECU will not power down if A6 is connected to constant VBat.
- Pin B5 needs to be supplied VBat to power the H-Bridge drivers (AUX3/4/HB1 and AUX5/6/HB2). These drives will not function if B5 is unpowered.
- CAN 1 has a +14V 3A cont. power output from the ECU for the CAN Bus. CAN 1 power out is sufficient to power a CAN Lambda.

Grounding

Grounding of the ECU should always be done to a single common point on the engine block or heads to reduce any voltage potentials between sensors and ECU grounds, and prevent ground loops.

⚠ Failure to ground the ecu to the engine can introduce inaccuracies in sensor readings.

- For any sensors with a ground pin on the sensor, only ground these to shield or sensor grounds on the ECU.
- Ensure the engine is well grounded to bat negative.

ADIO

G5 Voodoo Neo 4 and 6 bring ADIO pins to our ECU range. ADIO pins can function as Auxilliary Outputs, Analogue Volt Inputs, and switched Digital Inputs.

- When functioning as **Auxiliary Outputs**, ADIOs can be used as either switched (on/off) or PWM output.
- ECU ADIOs are Low-Side output only (switching ground) and have a weak pull-up resistor.
- When functioning as **Analogue Volt Inputs**, ADIOs have an analogue measurement range of 0 to +5V. +14V on these pins will not damage the ECU, but the value will not display over +5V.
- When functioning as **Digital Inputs**, ECU ADIOs can only be used for switched applications (not PWM).
- When functioning as **Digital Inputs**, ADIOs can use a configurable pull-up resistor to detect when a pin is grounded.

G5 Voodoo Neo 6 – Header A

Viewed looking into ECU header
(or wire side of loom connector)

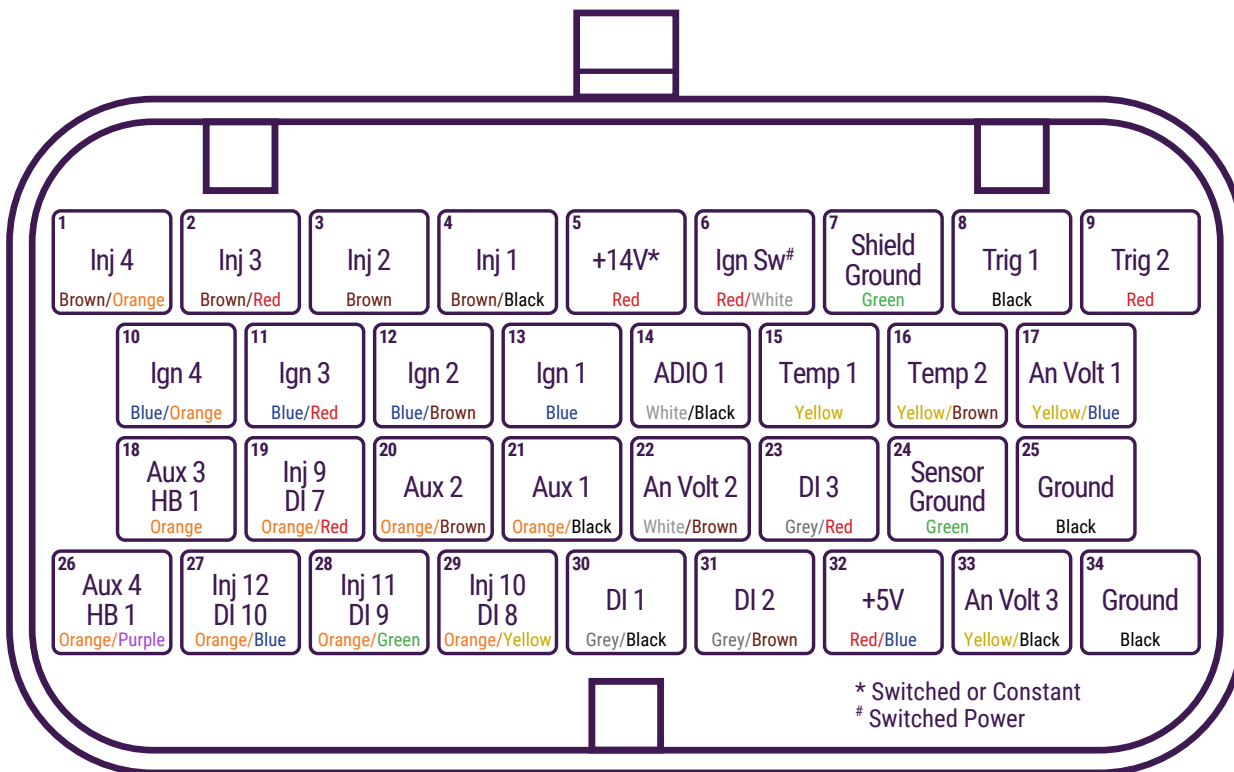

G5 Voodoo Neo 6 – Header B

Viewed looking into ECU header
(or wire side of loom connector)

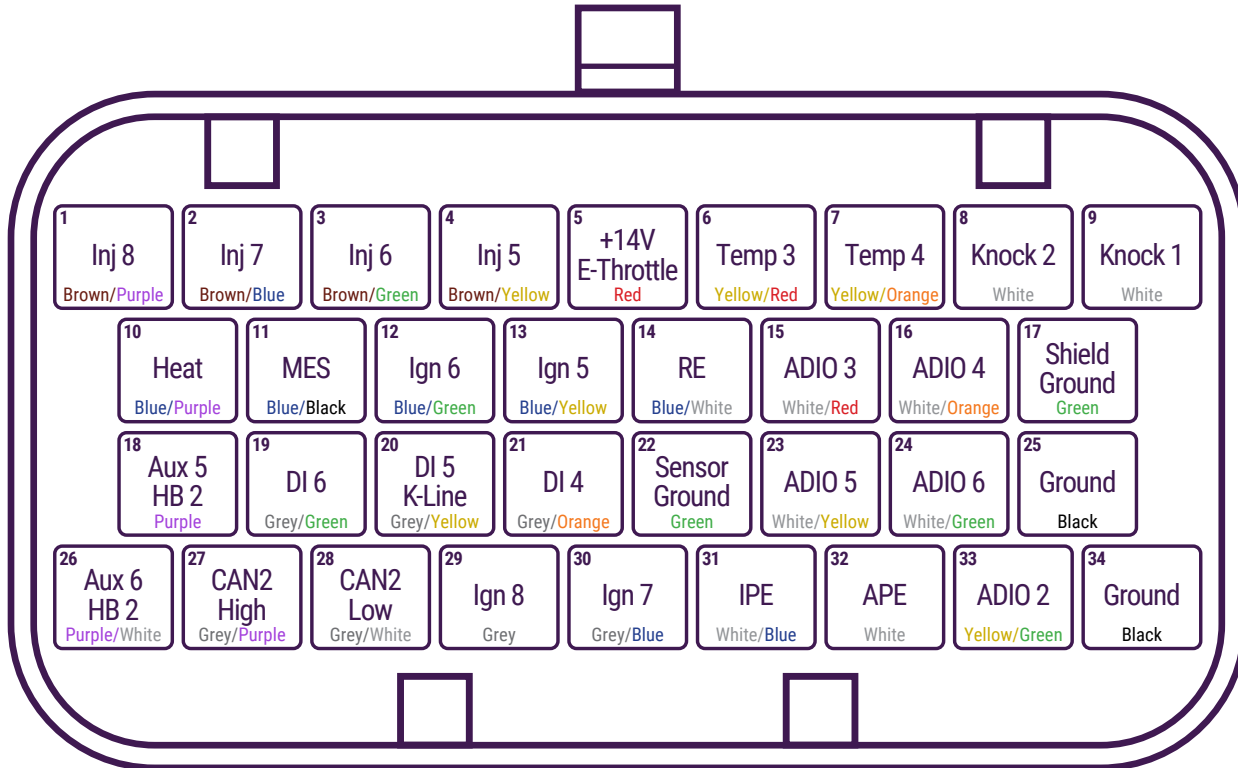

I/O Connectors

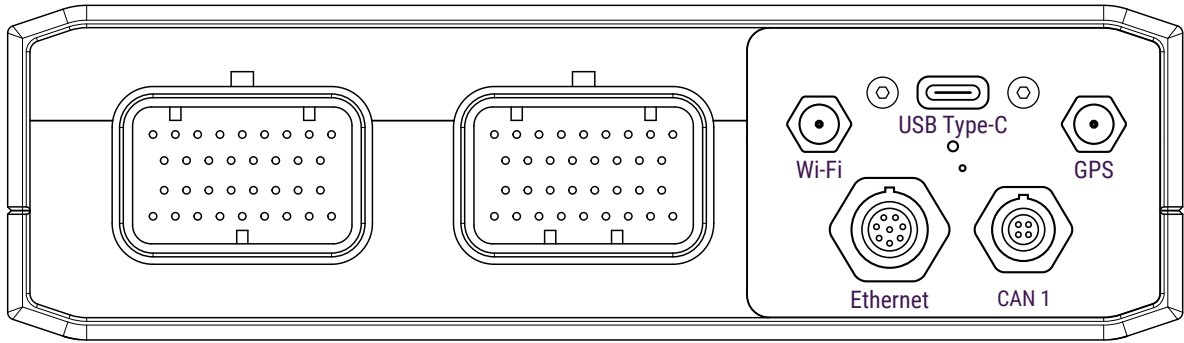

A Header

B Header

Communications Panel

Ethernet - WEiPU SF810B/P8

- 1. Orange/White
- 2. Orange
- 3. Green/White
- 4. Green
- 5. Blue/White
- 6. Blue
- 7. Brown/White
- 8. Brown



CAN 1 - WEiPU SF610B/P4

- 1. Ground Black
- 2. CAN Low Green
- 3. CAN High White
- 4. Power Red



Note: Orientation of pin 1 on the WEiPU connectors is relative to the locator notch in the connector, not the mounted orientation

*Wi-Fi Connector: RP-SMA standard (reverse polarity)
GPS Connector: SMA standard*