



G5 VOODOO PRO V2

Quick Start Guide

Document Version 1

**EXHILARATION
STARTS HERE**

IMPORTANT INFORMATION

Limited Lifetime Warranty

We stand behind what we sell, and our Limited Lifetime Warranty means no tricks, no catches. If an ECU breaks in the normal course of its designed use then we will repair or replace, no questions asked.

For full details, please visit:

linkecu.com/about/legal/lifetime-warranty/

The legal use of our products

Link Engine Management products should not be used where installation and tuning of such products contravenes your country's laws, interferes with the vehicle's safety or pollution protection features, or bypasses, defeats, or renders inoperative any emissions control system.

Link ECUs are shipped locked

All Link ECUs are shipped locked for anti-theft and must be unlocked before they can be used. Please contact your official LinkECU supplier to obtain an unlock code.

PCLink software

All Link ECUs are tuned and configured using our PCLink software. Connection to the ECU is established through on-board USB, Ethernet, or Wi-Fi.

Once you have the ECU connected to PCLink, check the ECU firmware and upgrade to the latest version.

Support options

There are a range of ways to find information and support for installing and using your ECU:

- PCLink help — **press F1** while running PCLink. Includes help on wiring, PCLink and ECU functions.
- Online Discussion Forum: forums.linkecu.com

Product and software manuals are available at:
linkecu.com/software-support/



Product knowledge base available at:
kb.linkecu.com/ecu-kb/latest



WIRING INFORMATION

Power

- Pin A5 is the main ECU power input. It can be supplied with either switched or constant VBat.
- Pin A6 is the ignition switch input. It must be connected to a switched battery source. The ECU will not power down if A6 is connected to constant VBat.
- Pin B5 needs to be supplied VBat to power the H-Bridge drivers (AUX1/2/HB1 and AUX3/4/HB2). These drives will not function if B5 is unpowered.
- CAN 1 has a +14V 3A cont. power output from the ECU for the CAN Bus. CAN 1 power out is sufficient to power a CAN Lambda.

Grounding

Grounding of the ECU should always be done to a single common point on the engine block or heads to reduce any voltage potentials between sensors and ECU grounds, and prevent ground loops

⚠ Failure to ground the ecu to the engine can introduce inaccuracies in sensor readings.

- For any sensors with a ground pin on the sensor, only ground these to shield or sensor grounds on the ECU.
- Ensure the engine is well grounded to bat negative

ADIO

G5 Voodoo Pro features 8 ADIO pins. ADIO pins can function as Auxilliary Outputs, Analogue Volt Inputs, and switched Digital Inputs.

- When functioning as **Auxiliary Outputs**;
ADIO 1-4 are Low-Side output only, Switched or PWM,
ADIO 5-8 can Low-Side output, Switched or PWM,
ADIO 5-8 can High-Side output, Switched.
- When functioning as **Analogue Volt Inputs**, ADIOs have an analogue measurement range of 0 to +5V. +14V on these pins will not damage the ECU, but the value will not display over +5V.
- When functioning as **Digital Inputs**, ECU ADIOs can only be used for switched applications, and can not read PWM (frequency).
- When functioning as **Digital Inputs**, ADIOs can use a configurable pull-up resistor to detect when grounded.

MOUNTING INFORMATION

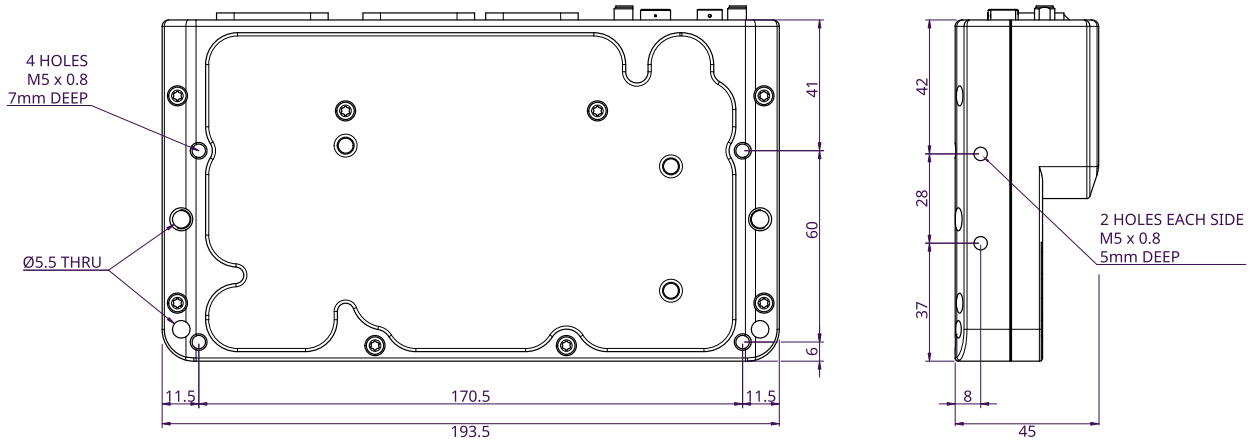

Several mounting options have been designed into the case:

- 4x Through-holes to suit M5 bolts.
- 4x Side mount M5 threaded holes.
- 4x Underside mount M5 threaded holes.

3 lengths of M5 button head cap screws have been included in the box to cover most mounting scenarios.

DO NOT make use of the threads in the mounting through-holes, these are included only for servicing, are an uncommon size, and are not intended for mounting.

- Recommended torque for mounting screws is 3 Nm (25 in-lb, 2.2 ft-lb).
- It is recommended that the ECU is rubber mounted in order to isolate the ECU from vibration.
- Mount where the ECU will not be exposed to excessive heat or moisture

I/O CONNECTORS

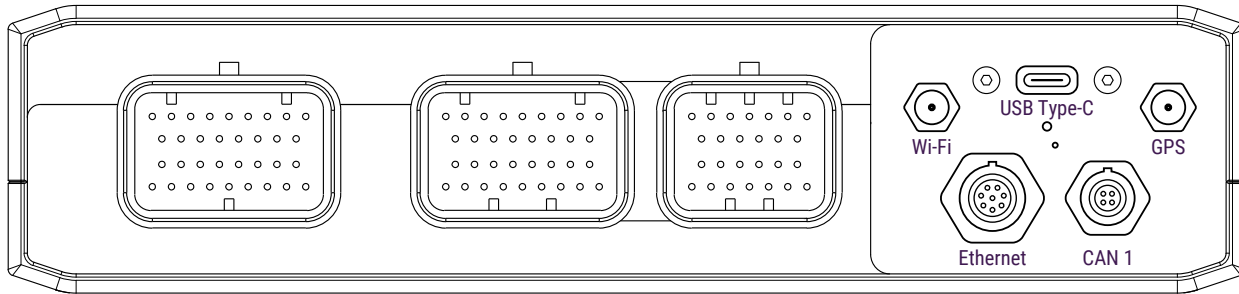

A Header

B Header

E Header

Communications Panel

Ethernet - WEiPU SF810B/P8

1. Orange/White
2. Orange
3. Green/White
4. Green
5. Blue/White
6. Blue
7. Brown/White
8. Brown



CAN 1 - WEiPU SF610B/P4

1. Ground
2. CAN Low
3. CAN High
4. Power

- Black
Green
White
Red



Note: Orientation of pin 1 on the WEiPU connectors is relative to the locator notch in the connector, not the mounted orientation

Wi-Fi Connector: RP-SMA (reverse polarity)

GPS Connector: SMA

G5 Voodoo Pro v2 – Header A

Viewed looking into ECU header
(or wire side of loom connector)

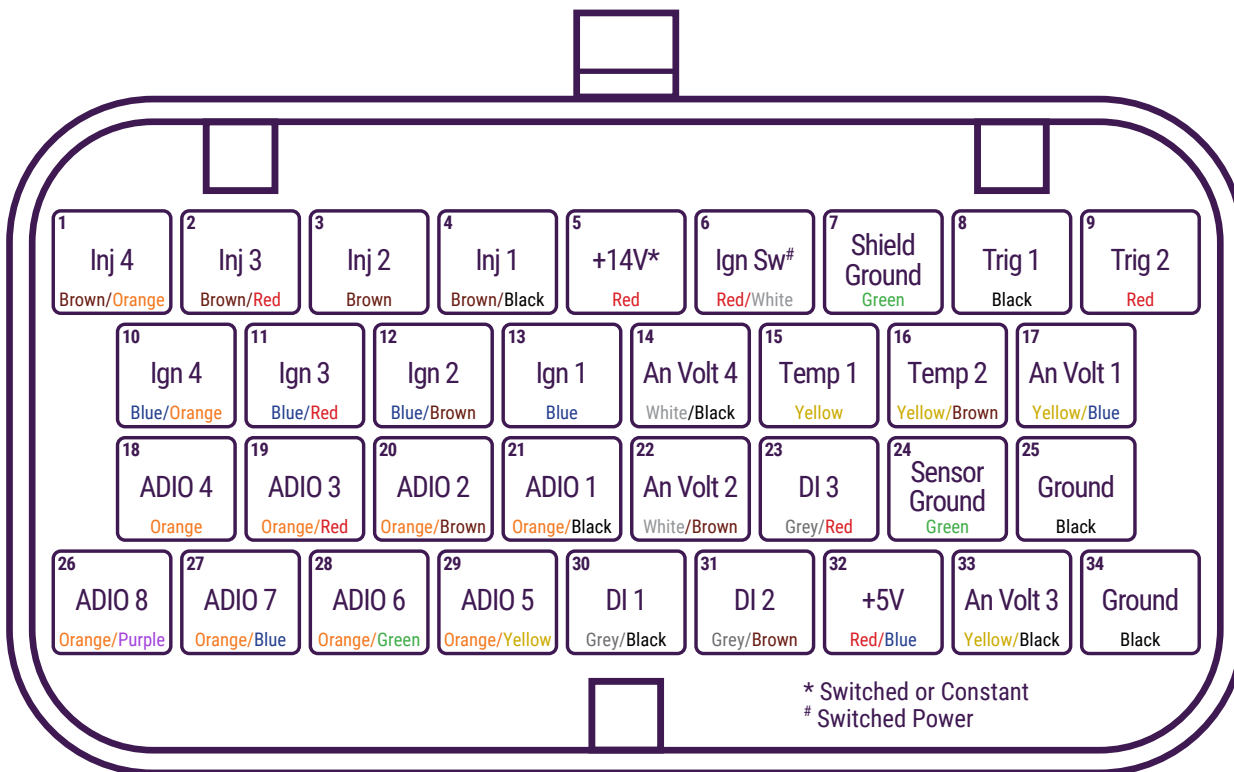

G5 Voodoo Pro v2 – Header B

Viewed looking into ECU header
(or wire side of loom connector)

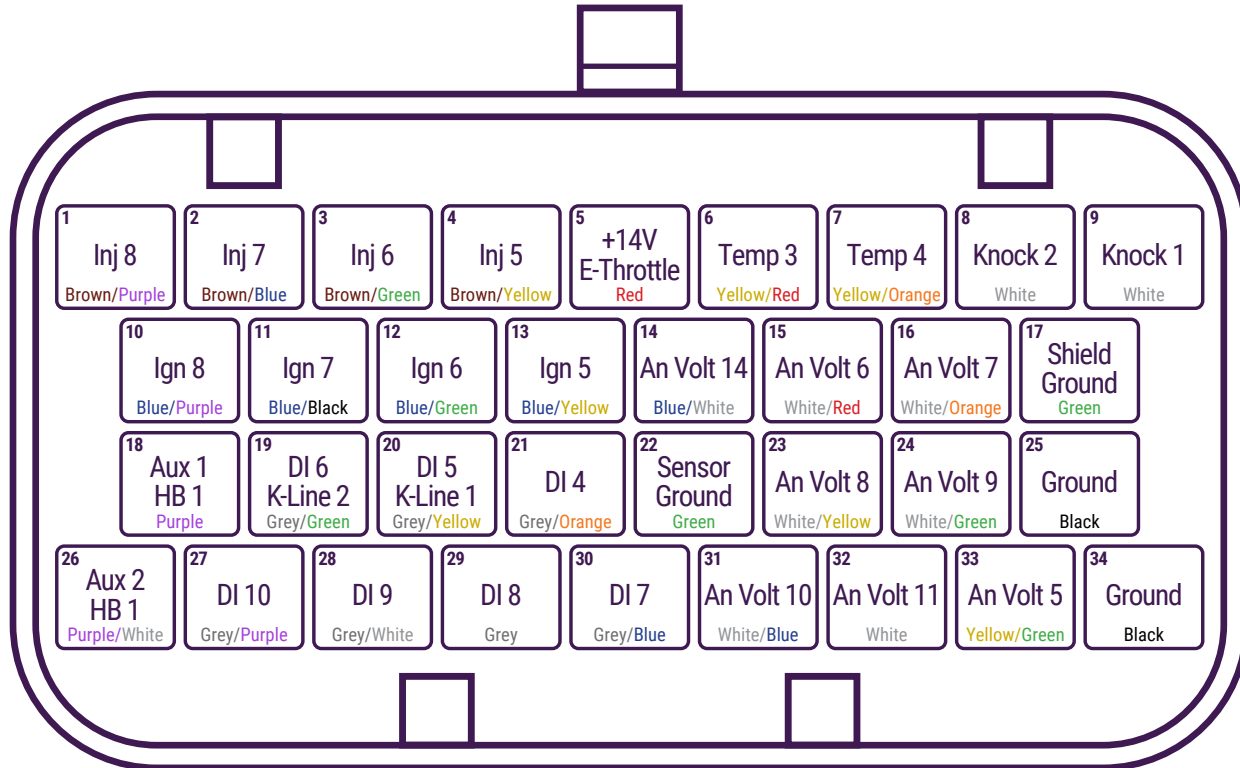

G5 Voodoo Pro v2 – Header E

Viewed looking into ECU header
(or wire side of loom connector)

